

Read 'awl' about it

Newsletter from

The Cannock Chase Shed



Issue No. 36

Submissions and suggestions to Bob Mason at:

shednewsletter@virginmedia.com

week ending Sat 17th 2021

In This Issue....

- Shed News
- Meet the Committee
- Notices
- Crossword No 14
- Spot the Difference
- Project – Dog Feeding Station
- Wordsearch – Manchester United
- Humour
- Latest Scams
- Project – Ping Pong Ball Launcher
- Answers to Puzzles

Well done to ALL the England team and management for lifting the country in the past weeks need to look to the world cup next with the experience gained lets hope that one comes home

Shed News

enquiries@cannockchaseshed.org.uk goes directly to all Committee Members to answer as necessary should anyone wish to give information or make any comment.

Check our webpage...

...for information about our Shed, updates about reopening and back issues of the newsletter.

<https://cannockchaseshed.org.uk/>

We are on Facebook...

Remember we have a Facebook page, where you can chat with friends, exchange ideas or ask for advice, as well as sharing your projects.

If you are having trouble finding the bits you need for your project, why not post a request? Another member may have just what you're looking for sitting unused in their garage, or they may know where you can get one.

If you have useful items that you are loath to throw away, why not put up a post, offering them to other members, before consigning them to the tip?

Official Facebook page: Private Group

<https://www.facebook.com/groups/cannockchaseshedders>

Meet the Committee

Dave Shaw	Chairman
Leslie Jukes	Deputy chairman
Barry James	Health & Safety
Avril Green	Fundraising/Secretary
Graham Johnson	Treasurer
Tim Cutler	Project Manager

Shed Media

Peter Ross	Website/Facebook Group
Bob Mason	Newsletter

Could you...



- Sort through your photos and send me a picture and a few words? – your pet, garden, favourite holiday, your most useful tool, a current or past project, a cooking success (or disaster) or favourite recipe? – Pretty much anything you like.
- send me a suggestion of something you'd like to see included in the newsletter? – anything from just a broad idea, to a finished article.
- send in a 'reader's letter'? Share an anecdote or treasured memory? Share your expertise with those who have less experience?
- Send in something else, or help in another way that I haven't even mentioned?

Or if your shy pass it to one of the committee!!!

Notices

Can any member wishing to book a session either on Monday morning or Monday afternoon on the 19th of July please phone me on 07964851114.

The hours for the morning are:

9-30am to 12-30pm

and the afternoon is:

1-00pm to 4-00pm.

Also, a reminder that to book a session you will need to have had both covid vaccine jabs or if you haven't had the jabs you will need to take a lateral flow test at least 12 hours before coming to the Shed.

I understand that most members prefer mornings because of other commitments in the afternoon but as we are now paying £15 a day could some members please try and book an afternoon, it would also spread out the amount of members in any one session. We will also need a supervisor for each session so if any member who is present at one of the sessions can do that it would be much appreciated.

Cleaning, washing up, tidying etc: needs to be started at least 15mins before the end of each session and maybe a little earlier in the afternoon as the keys have to be returned to the museum for 4-15pm.

Lastly, due to Government restrictions being extended until July 19th social distancing and wearing masks inside the Shed will still be required. If you don't have a mask with you, one can be supplied.

If anyone has changed their phone number or email address since first joining the Shed can they please send the new details to Graham at enquiries@cannockchaseshed.org.uk so he can update his records.

Diary Dates: **3rd August** – 10:30 Shed AGM (Provisional)

CCShed Membership status:

Extended Membership ends this month (June) and Annual Fees will again be due on 1st July 2021. Reduced this year to £17.50. Please pay Treasurer Graham direct by cash, cheque made out to Cannock Chase Shed or, direct debit giving your name and 'Fees' as Ref if there's room. Cannock Chase Shed. Sort Code 30 96 26 Account Number 47466468.

Crossword #14

Across

- 1. Conn. neighbor
- 5. Herringlike fishes
- 10. Leave in, to an editor
- 14. Ancient Andean
- 15. "Water Lilies" painter
- 16. Fiesta fare
- 17. Go to great heights
- 18. Itsy-bitsy bits
- 19. How one might run
- 20. Spanish gentleman
- 22. Mac maker
- 23. Wife, jokingly
- 25. Hindu soul
- 28. Aspen aficionado
- 29. Word after pocket or loose

1	2	3	4		5	6	7	8	9		10	11	12	13
14					15						16			
17					18						19			
20				21							22			
				23						24				
25	26	27				28								
29					30		31				32	33	34	35
36						37		38						
39							40		41					
					42				43		44			
45	46	47	48							49				
50						51						52	53	54
55						56						57		
58						59						60		
61						62						63		

- 31. Deliberate destruction
- 36. They may be pulled
- 38. Dilbert's workspace
- 39. Erotic
- 41. Early English comedy, "_____ Gurton's Needle"
- 42. "Get lost!"
- 44. Minuscule
- 45. Accept responsibility
- 50. Unaccompanied
- 51. Weatherman offerings
- 55. Lose steam
- 56. Parlor piece
- 57. Beat badly
- 58. Clothing line

- 59. Certain exams
- 60. Frank Herbert sci-fi series
- 61. Nothing but
- 62. To the point
- 63. A whole bunch

Down

- 1. Catchall abbr.
- 2. Forest ox
- 3. Wound covering
- 4. Minuet-like dances
- 5. Clothing size
- 6. Monopoly purchases
- 7. Polar parkas
- 8. Possessed one
- 9. Ave. crossers

- 10. Kind of infection
- 11. Buccaneers' home
- 12. Reason for a food recall
- 13. Representative
- 21. Spiny lobster
- 22. Like Cirque du Soleil performers
- 24. Fix, in a way
- 25. Plays a part
- 26. Quaker's "you"
- 27. "Death in Venice" author
- 30. Son of Cain
- 32. They're punched at work
- 33. Top of the heap

- 34. Secluded valley
- 35. Mysterious: Var.
- 37. Guaranteed
- 40. Russian urn
- 43. Diego Rivera creations
- 45. Weighty put-down
- 46. 1979 sci-fi classic
- 47. Snorkeling sight
- 48. Hostile force
- 49. Have a hunch
- 52. Music category
- 53. Spotify selection
- 54. Hearty dish
- 56. URL punctuator

Free printable courtesy of PrintitFree.net

SPOT THE DIFFERENCE

Can you spot the 8 differences between these two pictures?

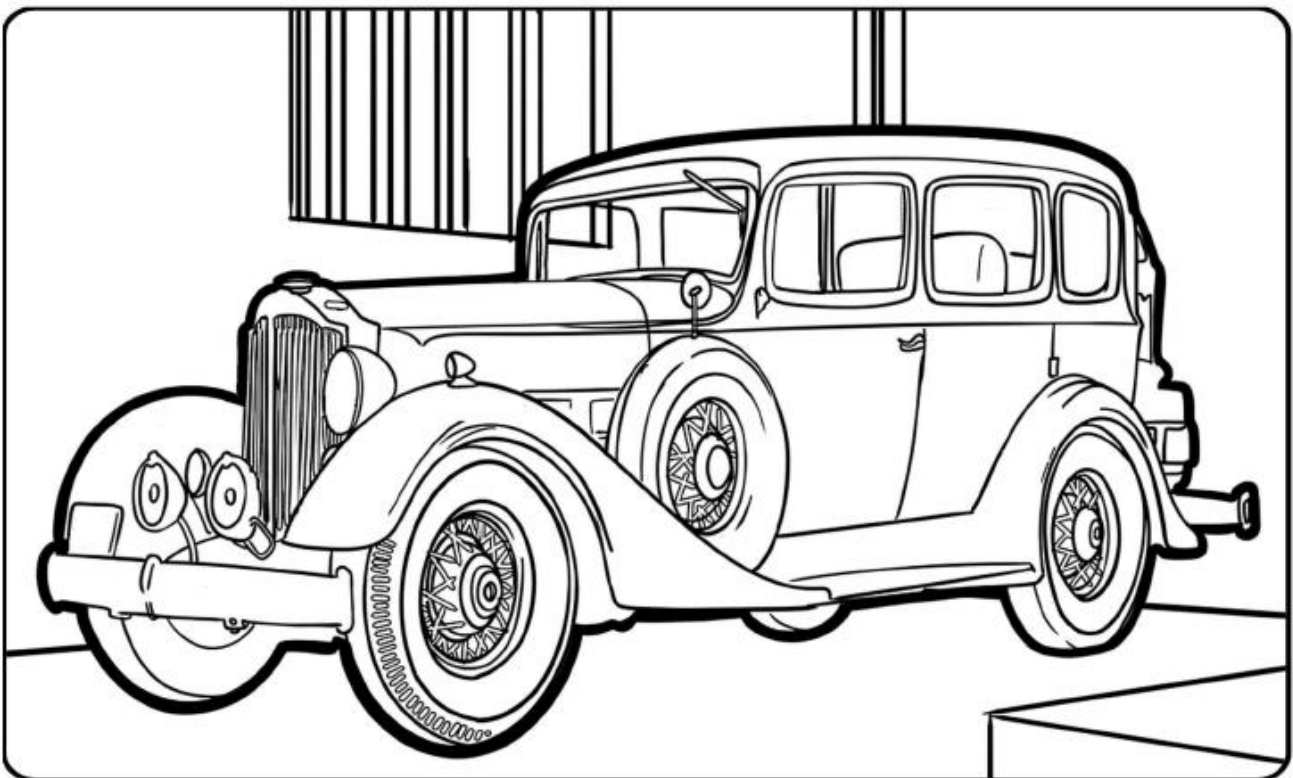
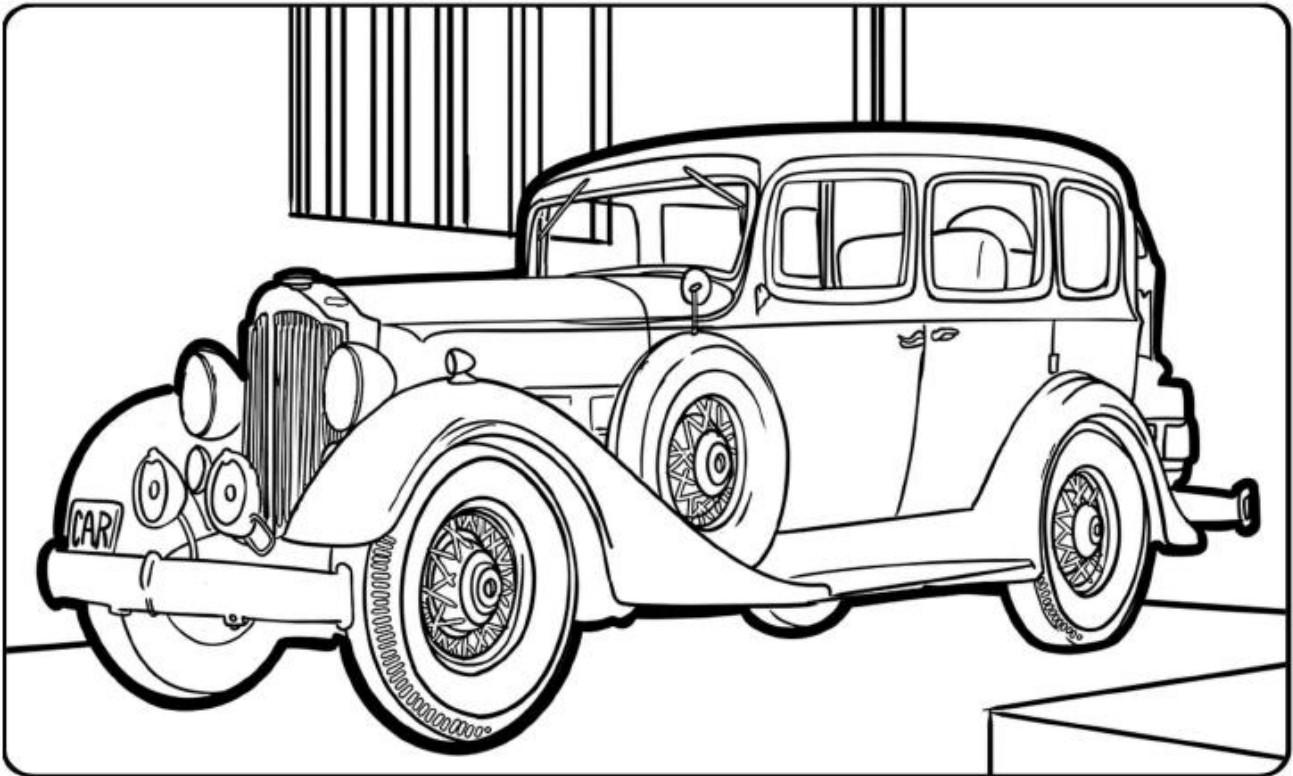

Project – Dog Feeding Station



WOODWORKS: ADVANCED PROJECT 2011-2012 DOG FEEDING STATION

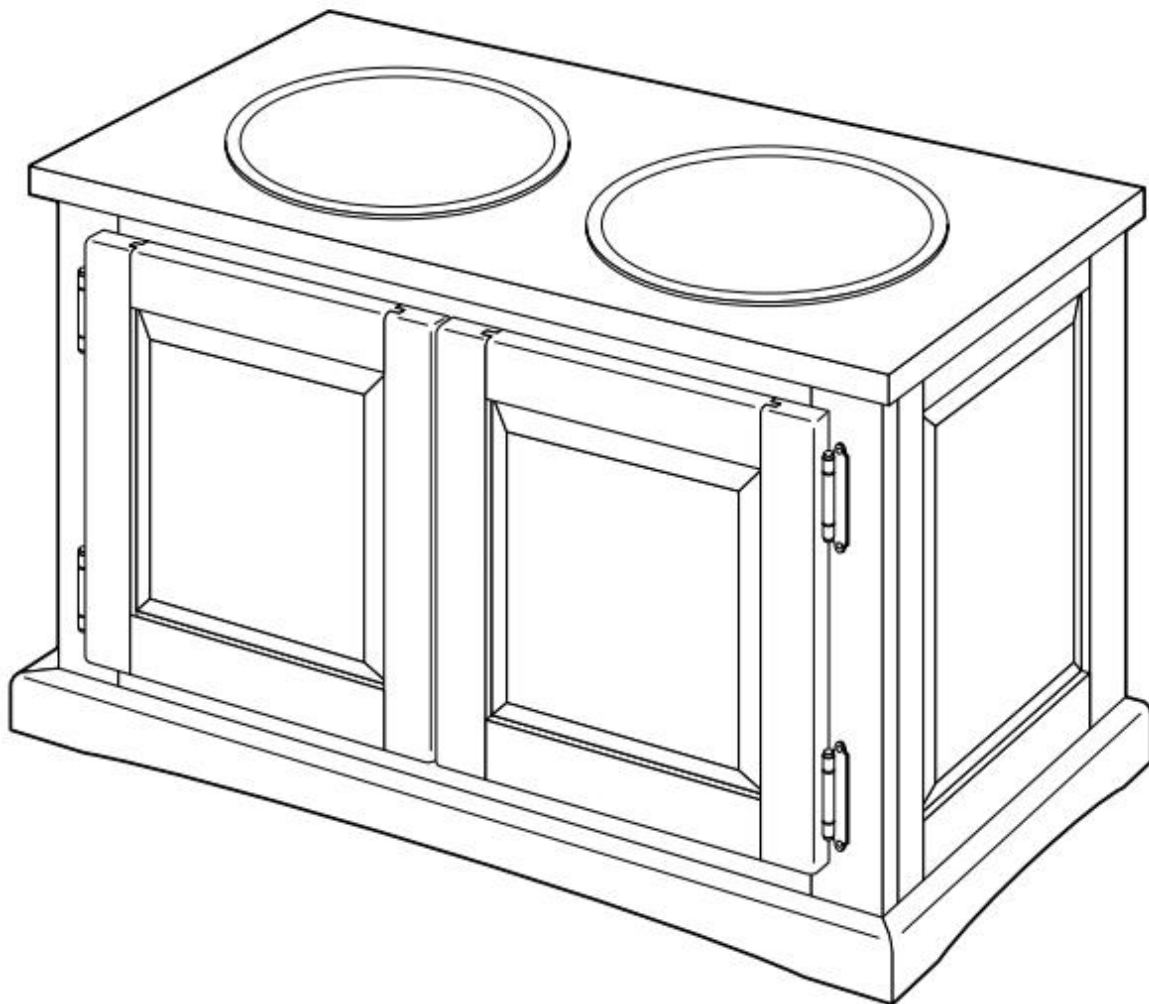

Here's a great way to give a little more love to your prized pet—a unique feeding station that puts the water and food bowls on a raised platform. It has a removable wood top for easy cleaning, and there's plenty of storage space below the bowls. The plan is based on a frame-and-panel assembly, although it could be simplified by using plywood for the sides and raised door panels. This particular piece was designed for a medium to large-size dog, but you can easily adjust the height to suit shorter breeds. It's a well-thought-out piece, great for advanced woodworkers, who'll get to practice their panel-raising and frame-building skills. And after you build it, you will learn more about applying and using finishes to protect the wood and keep it looking beautiful.

TOOLS REQUIRED

Hand Tools

- Pocket screw jig
- Sanding block
- Pipe or bar clamps
- Adjustable square

Power Tools

- Shaper or router table with tongue-and-groove cutter, 1/4" round-over cutter and 3/8" cove bit
- Biscuit joiner
- Table saw
- Miter saw
- Jigsaw
- Power drill with drill bits, Phillips-head screwdriver bit
- Orbital or finish sander

Miscellaneous

- Tape measure
- Pencil
- Wood glue
- Safety glasses
- 120-grit sanding belt
- 120-, 150- and 220-grit sandpaper
- Clean, lint-free cloths
- Respirator
- Gloves for finishing
- Mineral spirits, for cleanup of oil-based finishes
- Good quality, natural-bristle brush (for oil-based finishes)

SHOPPING LIST

Recommended Wood: Pine

Alternate Wood: Oak

Part	Material	Quantity
A through N	1' x 10' x 10' pine	1
O	1/4" fir plywood	1/2 sheet
Pocket hole screws	1-1/4" coarse thread	6
Pocket hole screws	1" coarse thread	8
Wood screws	#8 x 1-1/4" flathead	8
Table top fasteners		4
Door hinges		2 pair

CUTTING LIST

Overall Dimensions: 13" x 26-1/4" x 15-1/2"				
Part	Name	Qty	Th. x W x L	Notes
A	Top	1	3/4" x 13" x 26-1/4"	
B	Side stiles—front	2	3/4" x 1-1/4" x 13-1/4"	
C	Side stiles—back	2	3/4" x 2" x 13-1/4"	
D	Side rails—bottom	2	3/4" x 2" x 8-3/4"	
E	Side rails—top	2	3/4" x 1-1/4" x 8-3/4"	
F	Front stiles	2	3/4" x 2" x 13-1/4"	
G	Front rail—bottom	1	3/4" x 2" x 21-1/4"	
H	Front rail—top	1	3/4" x 1-1/4" x 21-1/4"	
I	Side panels	2	1/2" x 8-5/8" x 10-3/4"	
J	Upper and lower back rails	2	3/4" x 2" x 23-3/4"	
K	Cabinet bottom	1	1/4" x 11-3/4" x 25-1/4"	plywood
L	Door stiles	4	3/4" x 1-1/2" x 10-1/2"	
M	Door rails	4	3/4" x 1-1/2" x 8-9/16"	
N	Door panels	2	1/2" x 8-7/16" x 8-1/8"	
O	Back	1	1/4" x 13-1/2" x 24-1/2"	plywood
P	Base moulding	3	3/4" x 2" x 34" to make all 3 pieces	

WOOD FINISHING PRODUCTS

Recommended Finish

Prep: Minwax® oil based Pre-Stain Wood Conditioner
 Stain: Minwax® PolyShades® Natural Cherry Gloss
 Finish: Minwax® Helmsman® Spar Urethane – Gloss

Alternate Finish

Prep: Minwax® oil based Pre-Stain Wood Conditioner
 Stain: Minwax® Gel Stain Brazilian Rosewood
 Finish: Minwax® Helmsman® Spar Urethane – Semi-Gloss

BEFORE YOU BEGIN

Good craftsmanship begins and ends with good work habits, so make the following steps part of your routine workshop practice. If you have any doubts or questions about how to proceed with a project, always discuss them with your shop instructor.

- Carefully and fully review plans and instructions before putting a tool to the project lumber.
- Work sensibly and safely. Wear safety goggles when doing work that creates flying chips and sawdust; wear the appropriate respirator whenever making sawdust or working with thinners or other solvents.
- At the end of every work session, clean up your shop area and put away all portable tools.

CUTTING AND ASSEMBLY PROCEDURE

1. Glue up material as necessary to make top, A.

2. Measure the maximum diameter of the food bowls. The ones used here are 10". Then measure how wide the lip on top of the bowl is. Double that number and deduct it from the maximum diameter to determine the size hole needed for the bowls. In this case, the lip is 3/8", so the cutout for the holes is 9-1/4" (10" - 3/4").

Woodworker's Tip: *If you have a smaller dog, you can easily customize the feeder dimensions. For example, you can reduce the height to 8" by shortening parts B, C, F, I and O. Leave out the doors on the front, but don't close it in with a solid panel; it should be left open for cleaning. You can also reduce the cutouts for the bowls, if they're smaller than the ones in the plan.*

3. Rough cut all the frame pieces. Machine them to size.

4. Create rail and stile joints in side frame pieces, B, C, D, E. There are a variety of ways this can be done. In this case a tongue-and-groove router bit was used to create the groove in all eight pieces and the tongue on the end grain of the four rails. See Fig. 2.

5. Using a thickness planer, machine material for the side panels, I, to 1/2" thick. Cut them to size; the width of the panels is 1/8" less than the length of the rails to allow for seasonal changes. As a substitute, 1/4" plywood can be used to make a flat panel.

6. Machine the panel edges to make the raised panel. Remove enough material for the panel to fit into the grooves in the frame pieces. Sand the frame and panel pieces.

Woodworker's Tip: *It's best to finish the panel prior to gluing the frame and panel assembly together. See the finishing directions starting with Step 40.*

7. Glue the frame and panel together. Take the time to ensure that the assembly is perfectly flat and perfectly square. Because you're working with two different size stiles and two different size rails, be sure you glue the side frame assemblies as a left and a right.

8. Cut the front frame pieces, F, G, H to size. Using a pocket hole jig, bore two holes in each end of the 2" front rail, G, and one hole in each end of the 1-1/4" front rail, H.

9. Assemble the front frame using the 1-1/4" coarse thread pocket hole screws. Note that coarse thread screws are used for softwoods and man-made materials and fine thread are used for hardwoods. See Fig. 3.

10. Remove the side panels from the clamps. Measure the offset dimension of the tabletop fastener and add 1/16" to it. The result determines the location of the kerf to be cut in the top frame pieces to receive the fastener. In this case, the offset is 3/8", so the kerf is 7/16" from the top edge (3/8" + 1/16").

11. Set the distance from the fence to the table saw blade to the measurement determined in the previous step. Cut the kerfs for the tabletop fastener. Be sure that the top of each frame is against the fence.

12. Lay out and cut two biscuit slots on the front edge of the side frames and the back side of the front frame stiles, F. The slots should be spaced 2" from each end.

13. Using the table saw or a router table, cut a 1/4"-wide x 3/8"- deep rabbet on the back edge of the two side frames to receive the cabinet back, O.

14. Dry assemble the side panels to the front frame. Measure from side panel to side panel to determine the length of the upper and lower back rails, J.

15. Glue the side panels to the front frame. Check that the sides are perfectly perpendicular to the front.

16. Machine the back rails to size. Drill two pocket holes in each end of each piece. Install them.

17. Machine the door frame, L, M, and door panel pieces, N, to size. Make the frame and panel doors the same way as the frame and panel sides.

18. Machine the base molding, P, to width and rough cut it to length.

19. Using the router table, apply a 1/4" round-over to the top corner of the base molding.

20. Miter one end of the front molding and one end of one side of the base molding, leaving each piece long.

21. Make two 3/4" spacer blocks. Position the spacers even with the top of the bottom rail of the front frame. See Fig. 4. Slide the front molding against it, and test the miters. Adjust the miter angle as needed until there is a perfect fit.

22. Clamp the front molding so it's positioned perfectly for one miter. Mark the other end even with the case and then cut the second miter.

23. Cut one end of the next side molding and fit it to the front molding. Adjust the miter angle on the side molding until the fit is perfect.

24. Position the two side moldings on the case and mark them even with the back. Cut them to finished length.

25. Mark the curve on the bottom of the base moldings by measuring in 2" from each and 1/2" up in the center of the molding. Draw the curve by flexing a piece of hardboard against the layout marks and having another person trace the curve. See Fig. 5.

26. Cut the curves using a band saw or jigsaw. Sand the curves.

27. Glue and clamp molding in place. With all parts secure and properly positioned, drive screws from the inside of the case.

28. Sand the entire case and molding assembly. Remove doors from clamps and sand them.

29. Ease the corners of the doors using a 1/4" round-over bit.

30. Install a 3/8" cove bit in the router table. Set the depth of cut to 5/16" and rout a 2"- long cove in the top inside corner of each door to act as a pull. See Fig. 6. Sand the doors.

31. On the backside of the doors locate the hinges. One approach to this is to make the hinge even with the top or bottom of the door and mark the opposite edge of the hinge.

32. Install the hinges by placing them on the mark made in the previous step, pre-drilling and driving the hinge screws.

33. Mark the 1/4" door overlay on the front frame. Position one door on the marks and slightly back from the center of the frame. Secure it with one screw in each hinge.

34. Position the second door on the cabinet. Use a 3/32" spacer between the doors. Drill and drive just one screw in each hinge until positioning is perfect, allowing use of the second screw hole for small adjustments. When both doors are correctly set, drive the second screw into each hinge.

35. Cut and install the cabinet bottom, K. Cut and install the cabinet back, O.

36. Cut the top to final size. Using a 1/4" round-over bit, round all four corners on the top and three of the four corners on the bottom. Do not round the back edge on the bottom face.

37. Lay out the bowl locations on the top. Center the bowls across the width. Locate the left-to-right centers by adding the two bowl diameters together (measured below the rim), subtracting that from the length of the top, and dividing the remainder by three. The goal is to provide equal spacing from the end of the top of each hole, and also between the holes.

38. Use a compass to lay out the circles. Cut the circles using a jigsaw. Sand the inside of the bowl circles and then sand the top.

39. Place the top upside down on a bench, and the case upside down on the top. Fasten the case to the top using tabletop fasteners.

FINISHING TIPS

- Test the stains and finishes you are planning to use on scraps of wood. On the back of the scrap, mark the stain/finish combination and the type of wood. Allow all samples to dry thoroughly before

making your final finish selection. Save your samples for quick reference on future projects.

- All stains and finishes must be allowed to dry thoroughly between coats. Remember that drying times can vary due to humidity and other climatic conditions.
- If you have some leftover stain or finish, wipe the can rim so that stain or finish in the rim won't dry out and prevent the lid from forming a tight seal.
- Brushes used for oil-based finishes must be cleaned with mineral spirits.

40. Finish-sand any remaining rough spots with 220-grit sandpaper. Dust off the piece and wipe it carefully with a clean, lint-free lightly dampened cloth.

Recommended Finish

41. Before applying Minwax® PolyShades® to softwood, such as pine, apply Minwax® oil based Pre-Stain Wood Conditioner following the directions on the can. Applying a pre-stain conditioner will help ensure even absorption of stain and prevent blotchiness.

42. Apply Minwax® PolyShades® following the label directions. Use a good quality, natural- bristle brush suitable for use with polyurethane. Stir the can contents thoroughly before starting and periodically during your work session.

43. Dip the brush an inch or so into the can, gently tapping it against the inside to remove any excess. Apply a very thin, even coat following the direction of the wood grain. Make sure to maintain a "wet edge." To minimize brush marks and bubbles after staining, tip off the surface by holding the brush at a 45-degree angle and lightly run the bristles over the entire wood surface. Allow the first coat to dry at least 6 hours.

44. For the second coat, sand all surfaces lightly with 220-grit sandpaper or very fine (000) steel wool, using with-the-grain strokes. Dust off and wipe all surfaces with a cloth dampened with mineral spirits. Apply a second coat of PolyShades®, following the directions above. Set the project aside to cure overnight. To achieve a deeper color, you may apply a third coat after 4–6 hours, repeating the application directions.

45. For added protection from water and wear-and-tear, apply two coats of Minwax® Helmsman® Spar Urethane over PolyShades® following the directions on the can. Before applying, and in between coats, lightly sand the surface and remove all the dust. Stir well before and occasionally during use. Apply thin coats of Helmsman® using a good quality, natural-bristly brush. Allow the finish to cure for several days before installing the hardware and using the feeder.

Alternate Finish

46. Before using Minwax® Gel Stain on softwood, apply Minwax® oil based Pre-Stain Wood Conditioner, following the directions on the can. Applying the pre-stain conditioner will help ensure even absorption of stain and prevent blotchiness.

47. Before use and occasionally during the application, stir Minwax® Gel Stain until creamy.

48. Evenly apply a liberal amount of the Minwax® Gel Stain with a brush or rag. Wait 3 minutes and, using a clean rag, wipe with the wood grain to remove the excess. Allow Gel Stain to dry for 8–10 hours. To darken the color, apply additional coats of Minwax® Gel Stain.

49. For maximum protection, allow Gel Stain to cure for 24 hours. Then apply two coats of Minwax® Helmsman® Spar Urethane following the directions on the can. Before applying, and in between coats, lightly sand the surface and remove all dust. Stir Helmsman® well before and during use. Using a good quality, natural-bristle brush, apply thin coats. Allow the finish to cure for several days before installing the hardware and using the feeder.

PRODUCT SAFETY

For your safety and the safety of those you work with, always read the safety warnings, which manufacturers print on their labels, and follow them to the letter.

WARNING! Removal of old paint by sanding, scraping or other means may generate dust or fumes that contain lead. Exposure to lead dust or fumes may cause brain damage or other adverse health effects, especially in children or pregnant women. Controlling exposure to lead or other hazardous substances requires the use of proper protective equipment, such as properly fitted respirator (NIOSH approved) and proper containment and cleanup. For more information, call the National Lead Information Center at 1-800-424-LEAD (in U.S.) or contact your local health authority.

DANGER: Rags, steel wool, other waste soaked with oil-based stains and clear finishes, and sanding residue may spontaneously catch fire if improperly discarded. Immediately place rags, steel wool, other waste soaked with this product, and sanding residue in a sealed, water-filled metal container. Dispose of in accordance with local fire regulations.

When using oil-based wood finishing products:

CAUTIONS: CONTAINS ALIPHATIC HYDROCARBONS.

Contents are **COMBUSTIBLE**. Keep away from heat and open flame.

VAPOR HARMFUL. Use only with adequate ventilation. To avoid overexposure, open windows and doors or use other means to ensure fresh air entry during application and drying. If you experience eye watering, headaches, or dizziness, increase fresh air, or wear respiratory protection (NIOSH approved), or leave the area. Avoid contact with eyes and skin. Wash hands after using. Keep container closed when not in use. Do not transfer contents to other containers for storage.

FIRST AID: In case of eye contact, flush thoroughly with large amounts of water for 15 minutes and get medical attention. For skin contact, wash thoroughly with soap and water. In case of respiratory difficulty, provide fresh air and call physician. If swallowed, call Poison Control Center, hospital emergency room, or physician immediately.

DELAYED EFFECTS FROM LONG-TERM OVEREXPOSURE.

Contains solvents, which can cause permanent brain and nervous system damage. Intentional misuse by deliberately concentrating and inhaling contents may be harmful or fatal.

WARNING: This product contains a chemical known to the State of California to cause cancer and birth defects or other reproductive harm.

DO NOT TAKE INTERNALLY. KEEP OUT OF REACH OF CHILDREN. CONFORMS TO ASTM D-4326. Contact a physician for more health information.

FIG 1.

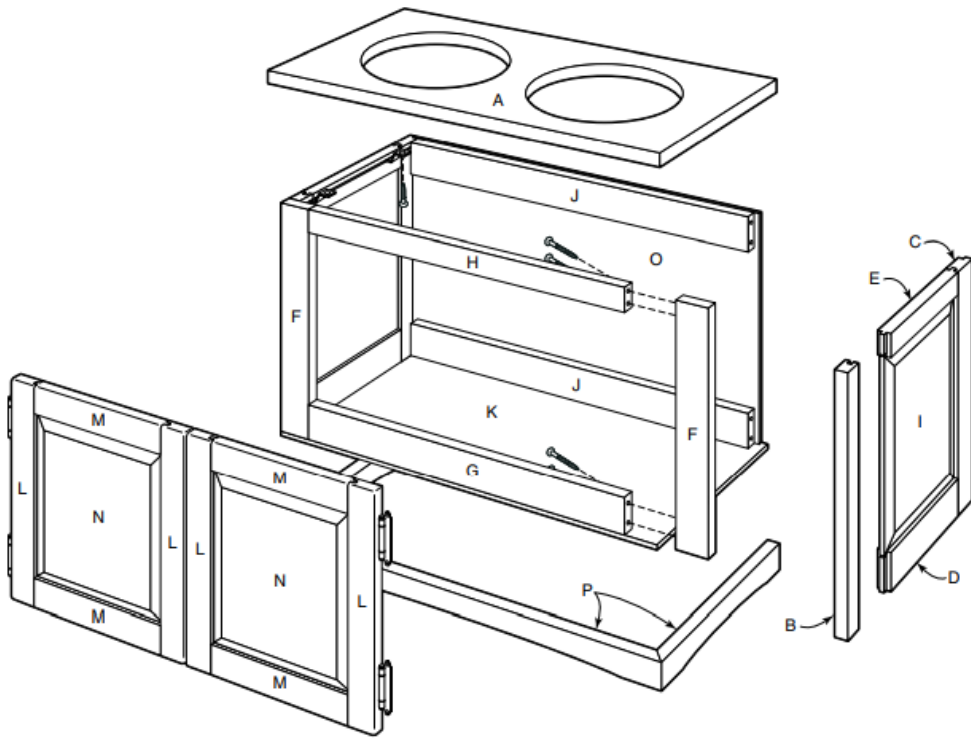

FIG 2.

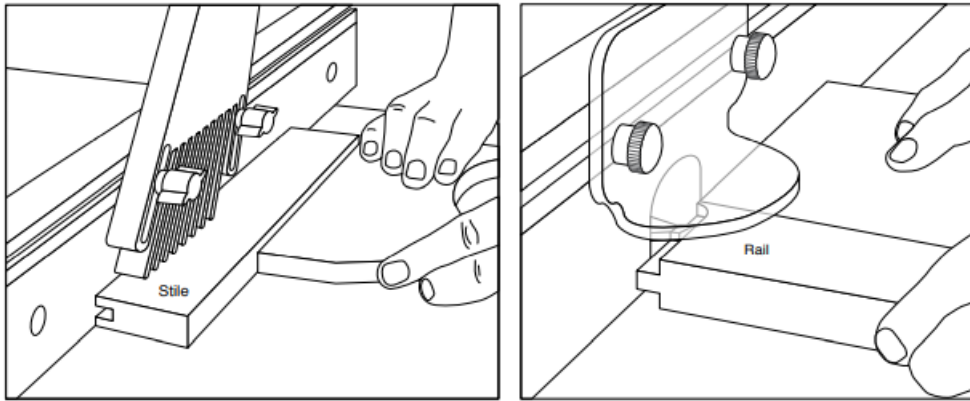

FIG 3.

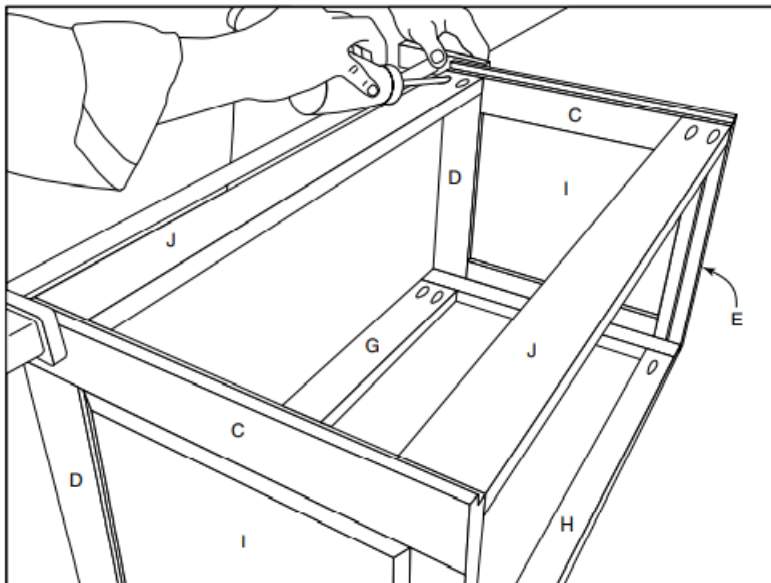

FIG 4.

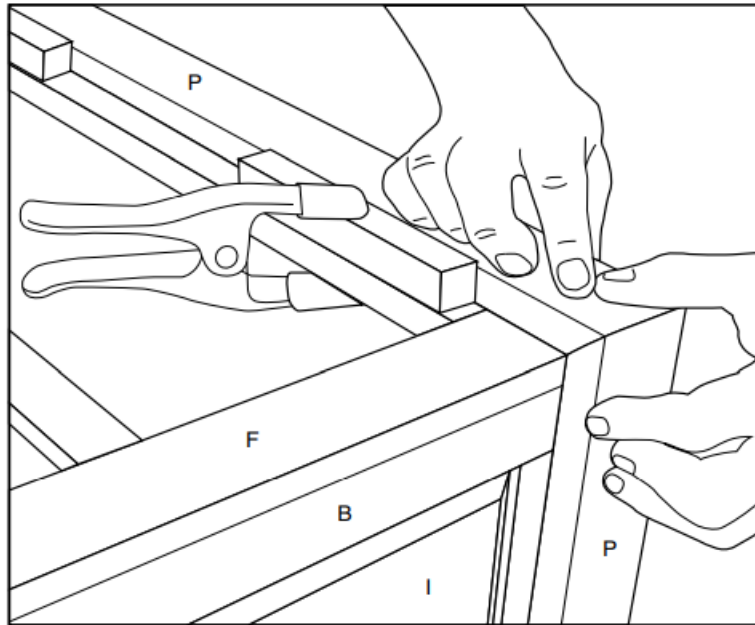

FIG 5.

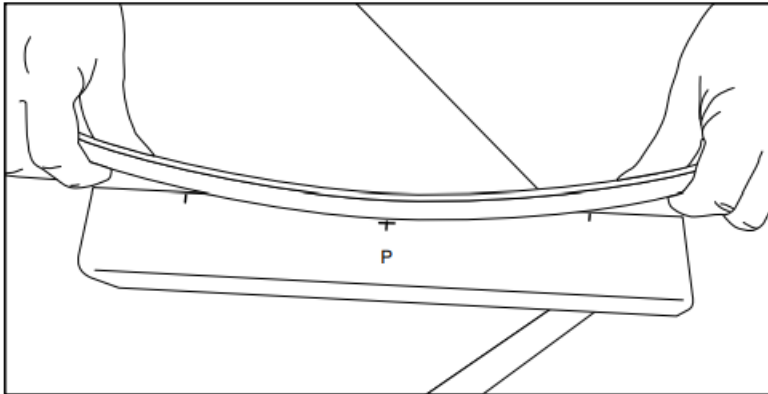
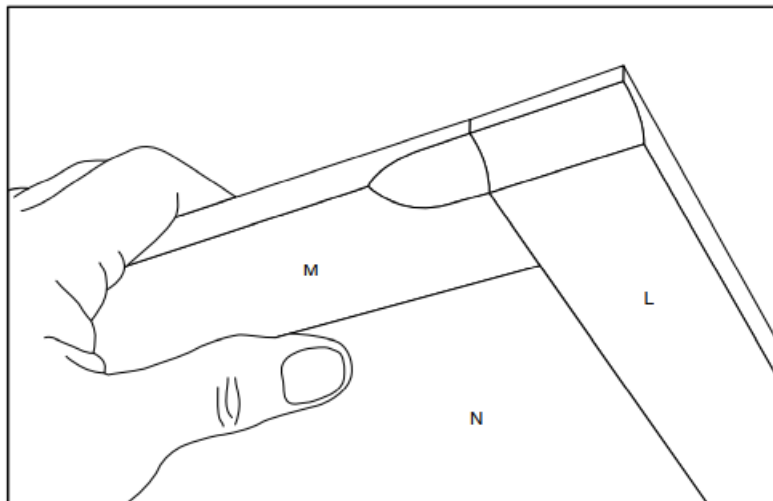

FIG 6.



Wordsearch – Manchester United

Manchester United

e	j	o	h	n	s	t	o	n	e	v	r	a	y	a	e	g	d	e	g
c	n	a	o	y	h	e	r	n	á	n	d	e	z	l	f	q	t	b	s
v	n	a	n	i	p	t	g	s	s	h	n	a	e	u	á	u	d	e	d
d	i	d	e	o	h	n	c	a	d	o	n	v	i	b	b	a	g	r	m
d	p	d	h	k	i	w	m	r	o	d	o	a	s	e	i	x	e	e	a
s	i	y	i	l	f	o	a	r	e	z	n	r	r	b	o	n	l	h	c
y	n	t	l	ć	s	a	o	r	e	x	o	e	e	e	t	z	e	c	h
y	i	a	g	i	g	g	s	u	k	k	t	l	p	t	b	a	a	t	e
a	m	s	v	e	k	o	q	c	c	c	t	a	ü	g	b	h	f	e	d
s	p	e	d	e	n	í	e	i	a	t	o	b	n	g	n	a	a	l	a
f	v	n	l	e	r	b	r	w	d	b	o	t	a	o	a	u	r	f	c
b	i	o	k	n	l	r	a	b	i	n	w	s	v	n	e	y	o	f	c
l	l	j	e	e	a	g	d	n	a	n	i	d	r	e	f	y	w	y	n
x	b	h	w	c	a	q	d	a	c	l	e	v	e	r	l	e	y	z	t
m	v	w	u	k	f	v	a	l	e	n	c	i	a	p	o	w	e	l	l

- | | | | |
|------------|------------|-----------|---------|
| ge | gea | hernández | macheda |
| rafael | vidić | büttner | |
| evra | carrick | wootton | |
| jones | nani | bebe | |
| ferdinand | young | keane | |
| evans | welbeck | amos | |
| valencia | van persie | johnstone | |
| anderson | henríquez | varela | |
| rooney | cleverley | zaha | |
| giggs | fletcher | fábio | |
| smalling | powell | | |
| lindegaard | kagawa | | |

Humour



Humour

I feel like I'm already tired tomorrow.

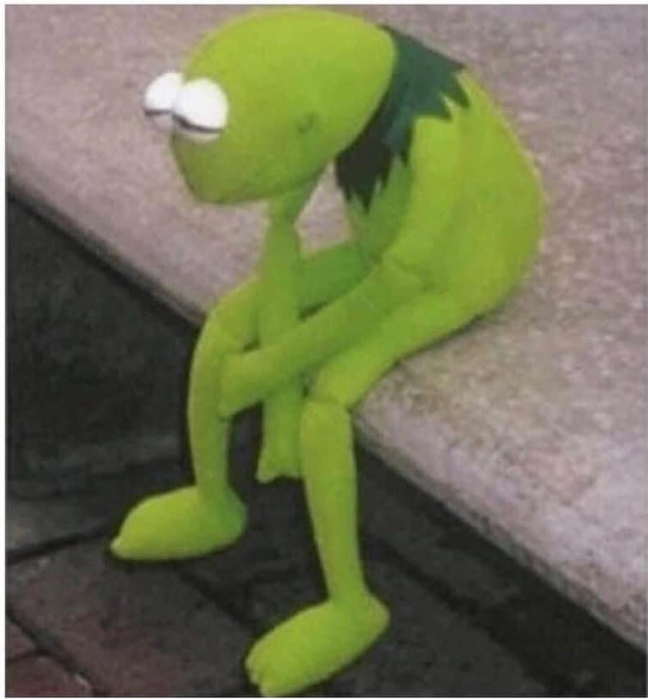

Sometimes you have to do it yourself if you want it done



Not only wearing
grumpy pants
today.
I have the
whole outfit
on and socks to match!



F1gur471v31y 5p34k1ng?

Good example of a Brain Study. If you can read this you have a strong mind.

7H15 M3554G3
53RV35 7O PROV3
HOW OUR M1ND5 C4N
DO 4M4Z1NG 7H1NG5!
1MPR3551V3 7H1NG5!
1N 7H3 B3G1NN1NG
17 WA5 H4RD BU7
NOW, ON 7H15 LIN3
YOUR M1ND 1S
R34D1NG 17
4U70M471C4LLY
W17H 0U7 3V3N
7H1NK1NG 4B0U7 17,
B3 PROUD! ONLY
C3R741N P30PL3 C4N
R3AD 7H15.
PL3453 FORW4RD 1F
C4N R34D 7H15

Humour

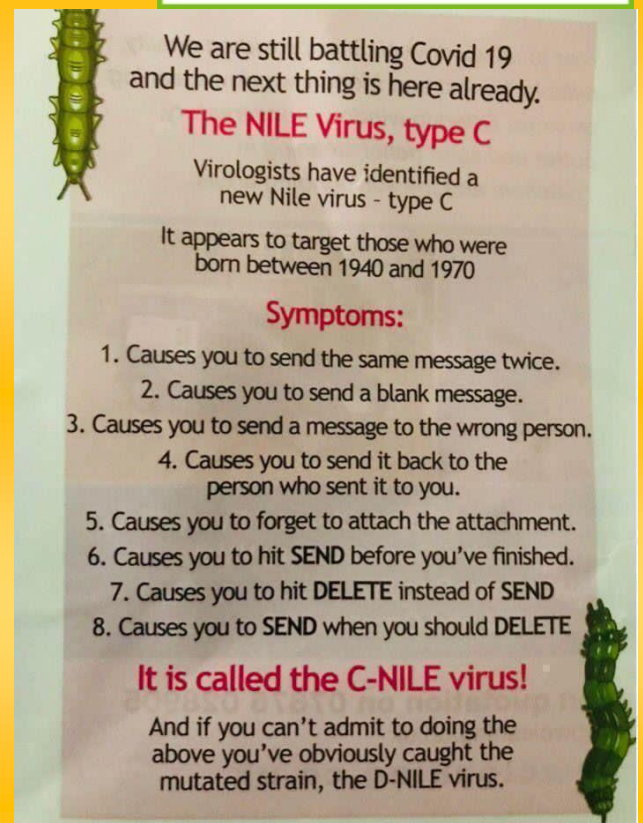
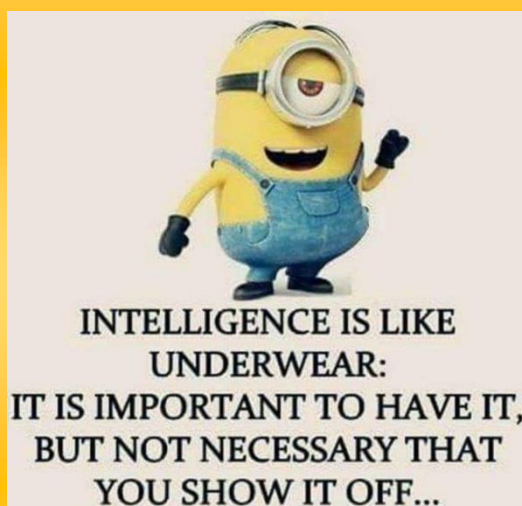
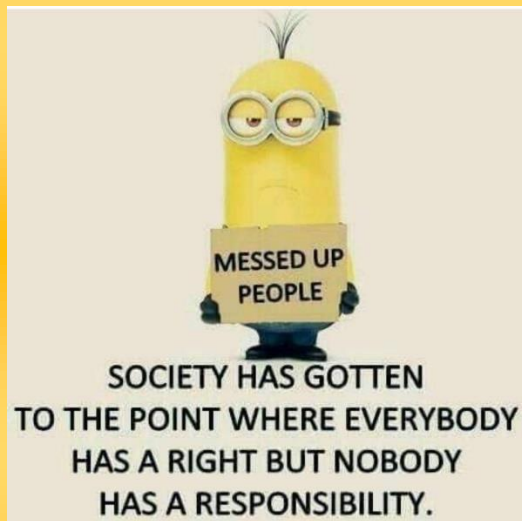

Latest Scams

Investment scams

If you come across an interesting investment opportunity via a search engine or online advert, how can you tell whether it's genuine or not? Just entering your email address and phone number on rogue investment sites could leave you facing a barrage of cold calls and unsolicited emails.

[In this video](#), we explain what checks you can carry out to ensure an investment site or firm is legitimate or a clone and how to stay one step ahead of fraudsters.

[Steps to check investment sites](#)

Will Google's new ad rules stamp out scams?

Several of our investigations found that scammers pay to appear at the top of Google search results – often posing as genuine financial services firms and luring would-be investors with the promise of high returns.

However, from September 2021, Google will introduce stricter requirements for firms promoting financial services in the UK. But how far does this protect you as a consumer?

We reveal [what Google is changing](#) and what this means for you.

[Changes to Google search](#)

Spot and protect yourself from scams

We've created [two scams protection checklists](#) to guide you through being able to spot scams and put settings in place to reduce the risk of a fraudster targeting you.

If you answer yes to any of these questions, there's a good chance it may be a scam.

[Our tips to spot and protect](#)

PS Please share this information with your friends, family and neighbours – anyone who may find it helpful. Or they can [sign up here](#) to receive this directly to their inbox.

You're receiving this email because you signed up to the Which? scam alert service.

Project – Ping Pong Ball Launcher

Video - <https://youtu.be/4IUteEMmh9g>

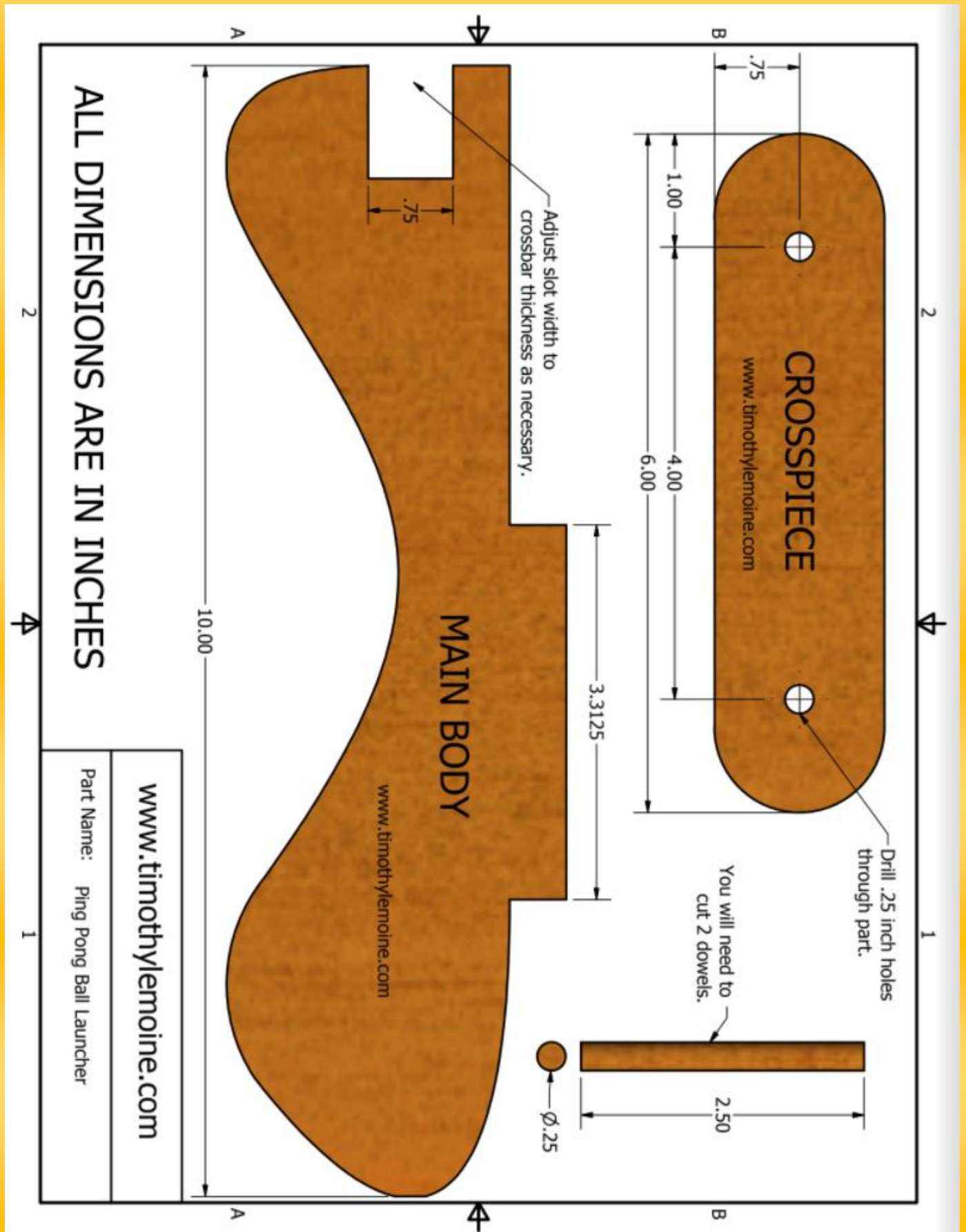

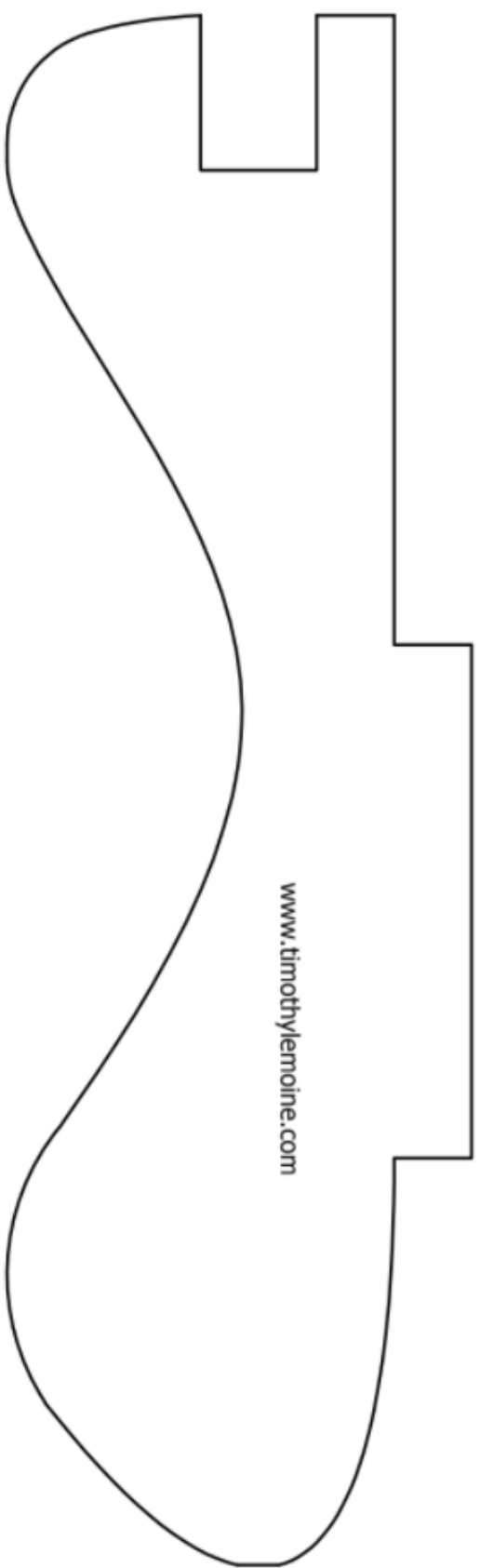

PRINTER FRIENDLY VERSION

When printing you SHOULD NOT select fit to page.
To print at actual size select "Original Size" or something similar.

www.timothylemoine.com

Part Name: Ping Pong Ball Launcher

2



1

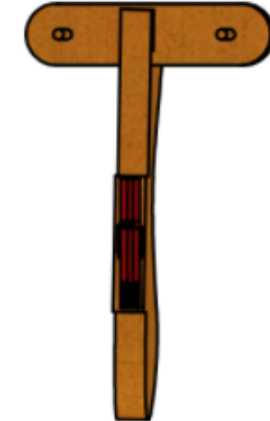

B

B



A

A



For detailed assembly instructions please visit
my YouTube Channel at:
https://www.youtube.com/c/TimothyLeMoine1Cor13_4-8

www.timothylemoine.com

Part Name: Ping Pong Ball Launcher

2



1

2



1



B

B

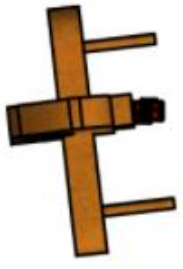

A

A

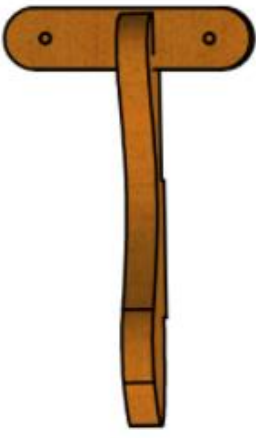

2



1

For detailed assembly instructions please visit my YouTube Channel at: https://www.youtube.com/c/TimothyLeMoine1Cor13_4-8

www.timothylemoine.com

Part Name: Ping Pong Ball Launcher

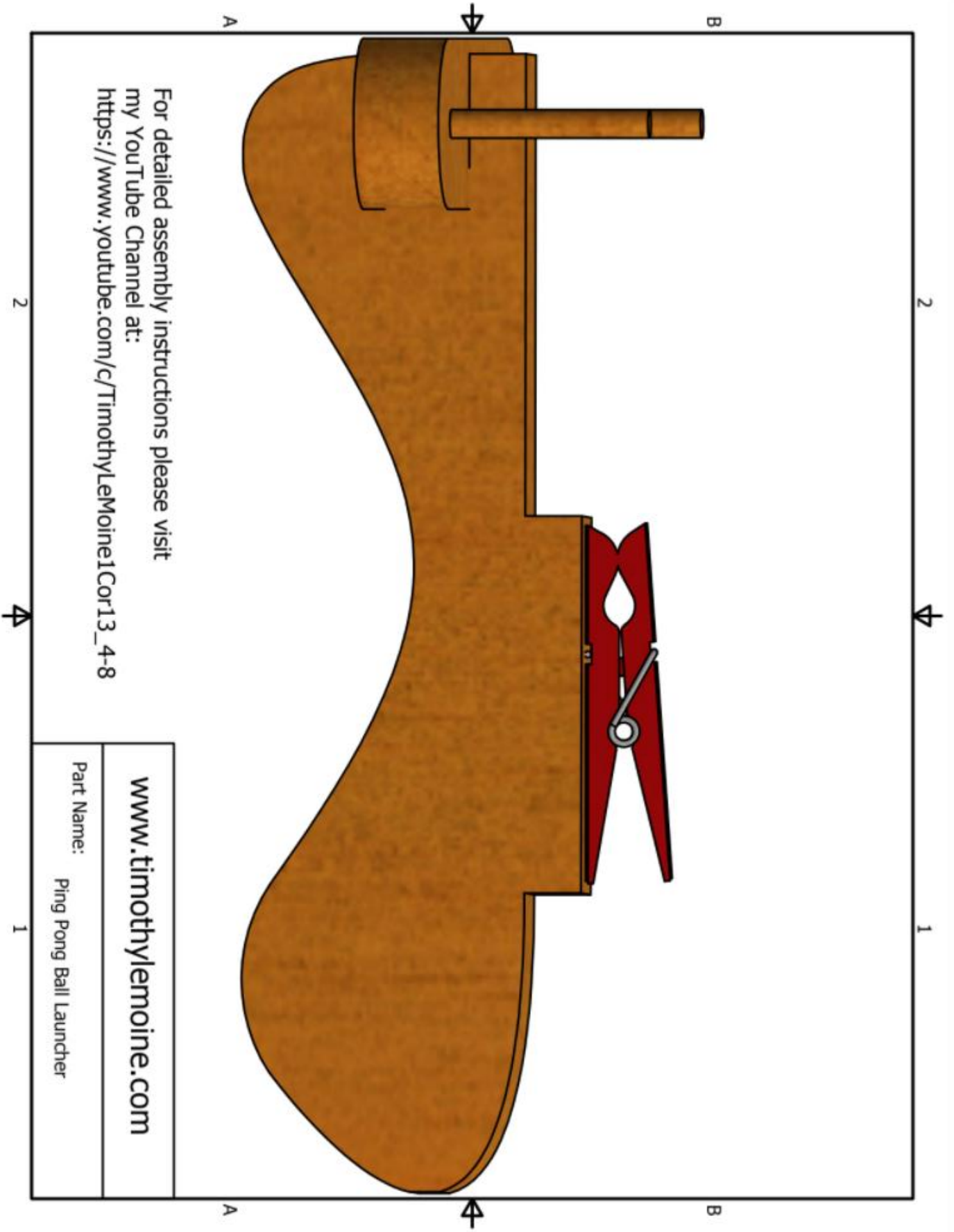

For detailed assembly instructions please visit
 my YouTube Channel at:
https://www.youtube.com/c/TimothyLeMoine1Cor13_4-8

www.timothylemoine.com

Part Name: Ping Pong Ball Launcher

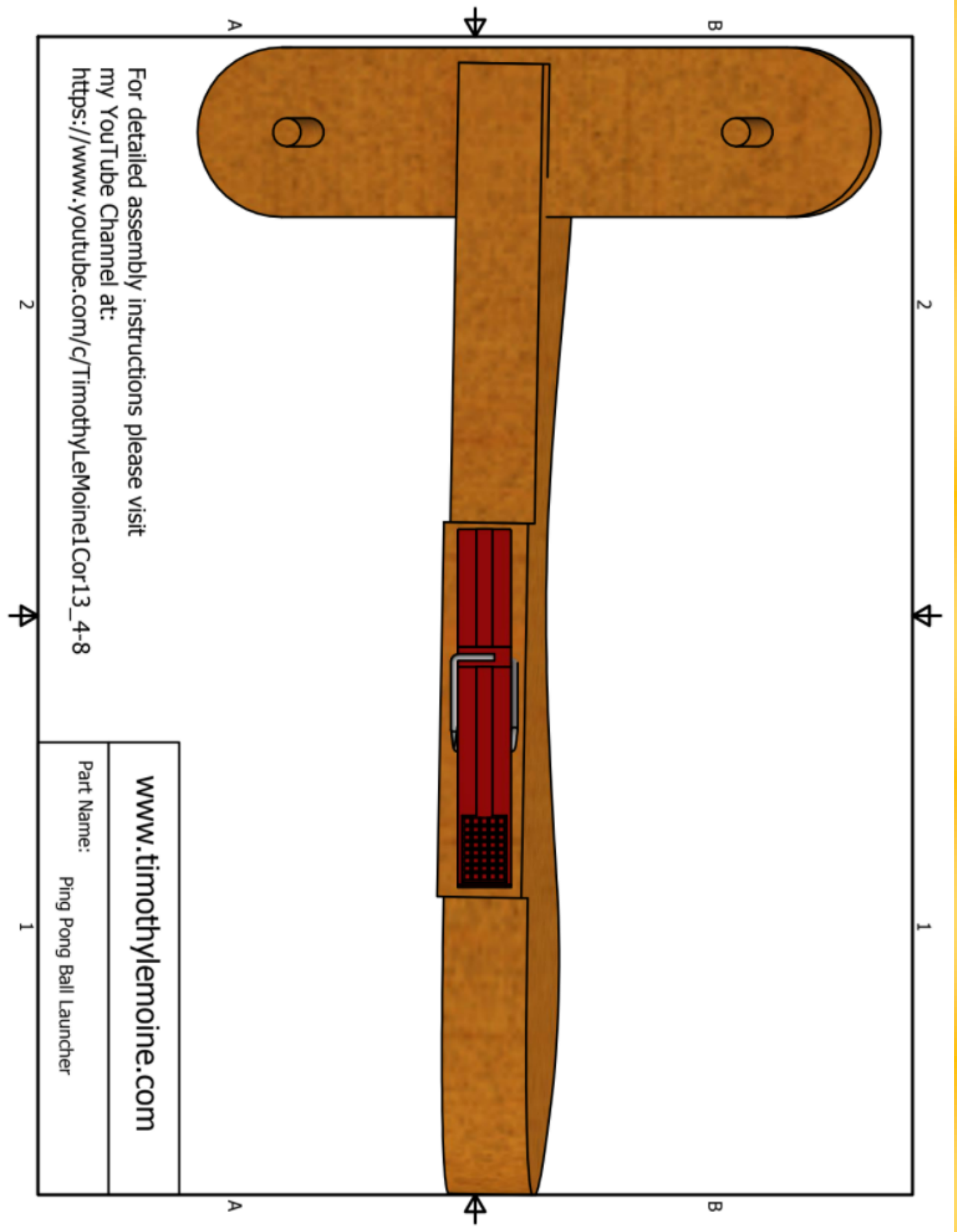

For detailed assembly instructions please visit
 my YouTube Channel at:
https://www.youtube.com/c/TimothyLeMoine1Cor13_4-8

www.timothylemoine.com

Part Name: Ping Pong Ball Launcher

Answers to Puzzles

Solution for Crossword #14

1	M	A	S	S		5	S	H	A	D	S		10	S	T	E	T			
14	I	N	C	A		15	M	O	N	E	T		16	T	A	C	O			
17	S	O	A	R		18	A	T	O	M	S		19	A	M	O	K			
20	C	A	B	A		21	L	L	E	R	O		22	A	P	P	L	E		
					23	B	A	L	L	A	N	D		24	C	H	A	I	N	
25	A	T	M	A	N		28	S	K	I	E	R								
29	C	H	A	N	G	E		30		31	S	A	B	O	T	A	G	E		
36	T	E	N	D	O	N	S		37		38	C	U	B	I	C	L	E		
39	S	E	N	S	U	O	U	S		40		41	G	A	M	M	E	R		
						42	S	C	R	A	M		43		44	T	E	E	N	Y
45	F	A	C	E	T	H	E	M	U	S	I	C								
50	A	L	O	N	E		51	F	O	R	E	C	A	S	T	S				
55	T	I	R	E		56	D	I	V	A	N		57	R	O	U	T			
58	S	E	A	M		59	O	R	A	L	S		60	D	U	N	E			
61	O	N	L	Y		62	T	E	R	S	E		63	S	L	E	W			

Manchester United

e	j	o	h	n	s	t	o	n	e	v	r	a	y	a	e	g	d	e	g
c	n	a	o	y	h	e	r	n	á	n	d	e	z	l	f	q	t	b	s
v	n	a	n	i	p	t	g	s	s	h	n	a	e	u	á	u	d	e	d
d	i	d	e	o	h	n	c	a	d	o	n	v	i	b	b	a	g	r	m
d	p	d	h	k	i	w	m	r	o	d	o	a	s	e	i	x	e	e	a
s	i	y	i	l	f	o	a	r	e	z	n	r	r	b	o	n	l	h	c
y	n	t	l	í	s	a	o	r	e	x	o	e	e	e	t	z	e	c	h
y	i	a	g	i	g	g	s	u	k	k	t	l	p	t	b	a	a	t	e
a	m	s	v	e	k	o	q	c	c	c	t	a	ü	g	b	h	f	e	d
s	p	e	d	e	n	í	e	i	a	t	o	b	n	g	n	a	a	l	a
f	v	n	l	e	r	b	r	w	d	b	o	t	a	o	a	u	r	f	c
b	i	o	k	n	l	r	a	b	i	n	w	s	v	n	e	y	o	f	c
l	l	j	e	e	a	g	d	n	a	n	i	d	r	e	f	y	w	y	n
x	b	h	w	c	a	q	d	a	c	l	e	v	e	r	l	e	y	z	t
m	v	w	u	k	f	v	a	l	e	n	c	i	a	p	o	w	e	l	l